

MAXXUM 101 hand control
101 LBS THRUST
36 VOLT 46 AMPS
52" SHAFT

for use with "AH" serial numbers
3-year warranty from the date of purchase

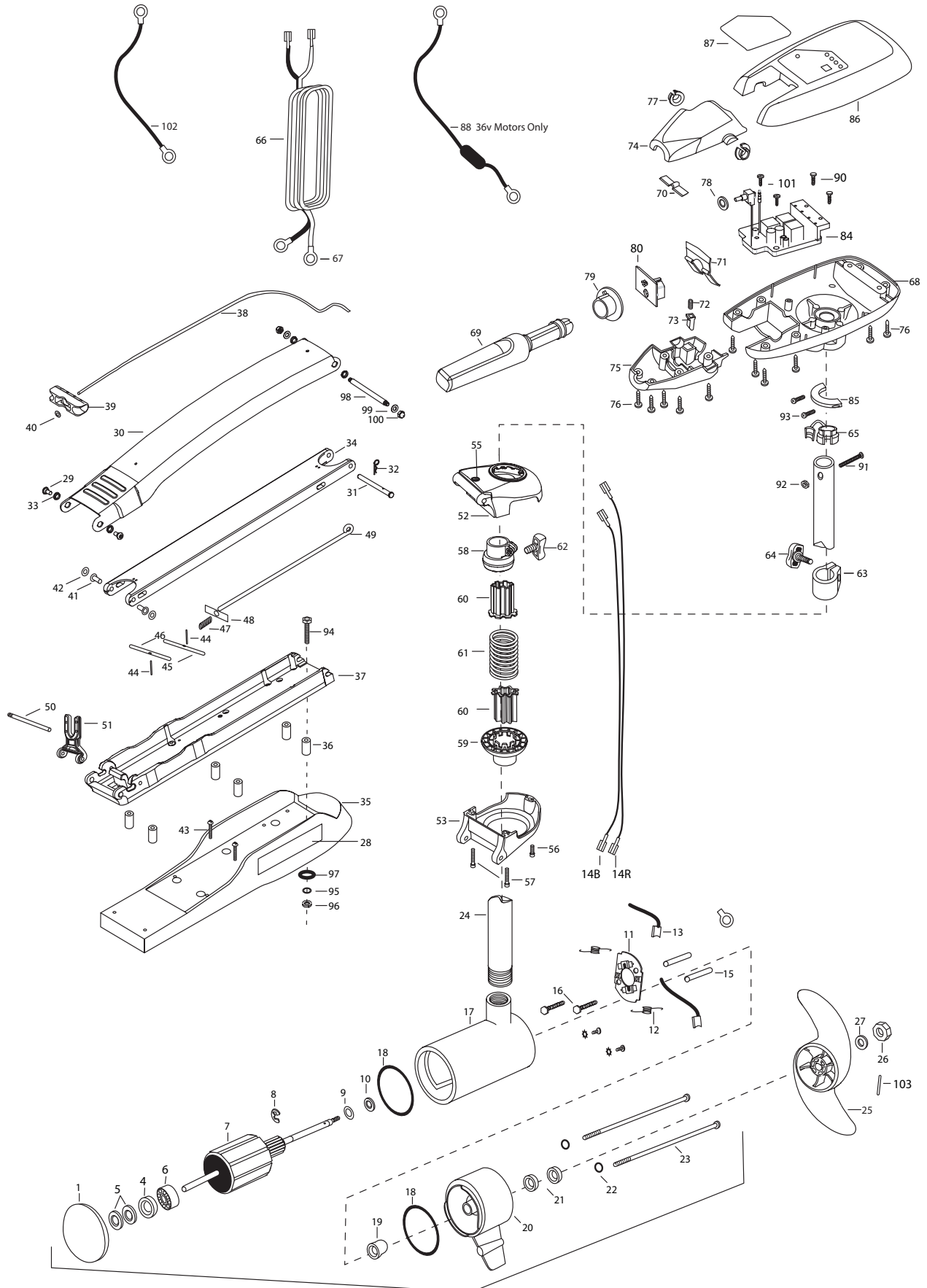

1	421-276	PLAIN END HOUSING ASSEMBLY		INCL 38-40, 44-49	70	2302742	SPRING-DETENT(OFF)
4	990-045	THRUST SPACER	35	2263912	71	2302743	SPRING-DETENT,HANDLE-TILT
5	992-010	SPRING WASHER [2.EA]	36	2261505	72	2302745	SPRING-RELEASE BUTTON
6	140-010	BALL BEARING	37	2773987	73	2303720	RELEASE BUTTON-HANDLE
7	2-100-216	ARMATURE ASSEMBLY	38	2251601	74	2060409	HANDLE (TOP HALF)MAXIMIZE
8	788-040	RETAINING RING	39	2150400	75	2060415	HANDLE (LOWER HALF)
9	990-051	WASHER-THRUST, STEEL	40	2151700	76	2303412	SCREW-6-20 X 5/8 SELF TAP [11.EA]
10	990-052	WASHER- NYLATRON	41	2261708	77	2060005	BEARING-HANDLE PIVOT [2.EA]
11	738-004	BRUSH PLATE -4" TERMINAL	42	2236000	78	2181700	WASHER, SPACER
12	975-041	SPRING -TORSION [2.EA]	43	2263434	79	2992852	ACTUATOR-CAM
13	188-094	BRUSH W/TERMINAL [2.EA]	44	2152610	80	2184020	POT ADAPTER
14B	640-018	BRUSH WIRE-BLK 62"	45	2233600	84	2184001	CTRL BOARD ASSEMBLY 24/36V
14R	640-123	BRUSH WIRE- RED 64"	46	2233602	85	2061515	COLLAR-CTRL BOX (FRS-WTR)
15	973-025	SPACER -BRUSH PLATE [2.EA]	47	2152700	86	2260290	CTRL BOX CVR- BLK
16	830-027	SCREW -SELF TRDED 10-32 X 2" [2.EA]	48	2262703	87	2265622	DECAL-COVER, MAX101/H
17	431-110	HOUSING ASSEMBLY- CENTER	49	2153602	88	2998200	CIRCUIT BREAKER ASSEMBLY36V-101
18	701-043	O-RING [2.EA]	50	2260506	90	2372100	SCREW-8-18 X 5/8 THD [2.EA]
19	144-017	BEARING -FLANGE (SERVICE ONLY)	51	2293811	91	2383407	SCREW-10-24 X 2." PPH ZINC
20	2-300-160	BRUSH END HOUSING ASSEMBLY	■	2994833	92	2383124	NUT-10-24 NYLOCK ZINC PLT
21	880-025	SEAL [2.EA]	■	2991760	93	2263434	SCREW-#8 X 1" PPH TYPE 25 SS [2.EA]
22	701-009	O-RING -THRU BOLT [2.EA]	52	2772319	■	2994830	BAG ASSEMBLY-MAXXUM
23	830-096	THRU BOLT 12-24 X 11.56" SS [2.EA]	53	2991770	*94	2263431	SCREW 1/4-20 X 3.5 PPH [6.EA]
■	2316285	MTR ASSEMBLY 36V 4" VARS [INCL.1-23]	55	2772352	*95	2261713	WASHER-1/4 FLAT S/S [6.EA]
24	2032068	TUBE-CARBON COMPOSITE 52"	56	2263423	*96	2263103	NUT-1/4-20 NYLOCK-JAM S/S [6.EA]
■	1378132	PROPELLER KIT	57	2263425	*97	2301720	WASHER-MOUNTING*RUBBER [6.EA]
25	2331160	PROPELLER- W/WEDGE 2	58	2261525	98	2262605	PIN BWGRD UPPER THREADED ZP
26	2093101	NUT-PROP,NYLOC (LARGE) MAX101	59	2261535	100	2223100	NUT- TENSION 5/16-18 SS [2.EA]
27	2091701	WASHER-PROP (LARGE) MAX 101	60	2264702	101	2301310	SCREW- #8-18X1/2 SS [2.EA]
28	2265514	DECAL- MAX MOTOR REST [2.EA]	61	2262704	102	2340610	CONNECTOR CABLE
■	2771866	MOUNT/BOWGUARD ASSEMBLY FW STD	62	2011365	103	2262658	DRIVE PIN
■	2991840	MOUNT BOW ASSY, FW STD, W/O BGRD	63	2031520			
29	2263500	BOLT, SHOULDER (MAXXUM) [2.ea]	64	2011365			
30	2264241	ARM-UPPER FW,STD	65	2052900			
31	2262607	PIN- CLEVIS ZP MAX BWGRD	66	2090600			
32	2260805	CLIP-SPRING ZP MAX BWGRD	67	2020700			
33	2293501	BUSHING, STAINLESS STEEL [4.EA]	68	2062592			
34	2994307	ARM-LOWER ASSEMBLY STD,FW,EXT	69	2990914			

Seal & O-Ring Kit is p/n 2889460

* This item is part of an assembly. This item cannot be sold separately due to machining and /or assembly that is required.

P/N 2274971 REV. E 6-06

